

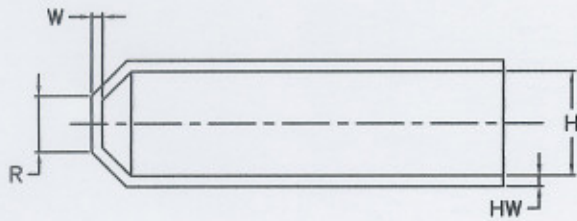

IKEBANA ENGINEERING LIMITED

ENGINEERING DRAWING :
HEAT SHRINKABLE CABLE ACCESSORIES

PRODUCT	END CAPS
MODEL	IXL 100 TO IXL 170
DOCUMENT NO.	DR/MFG/100
PAGE	1 OF 1



RECOVERED END CAP

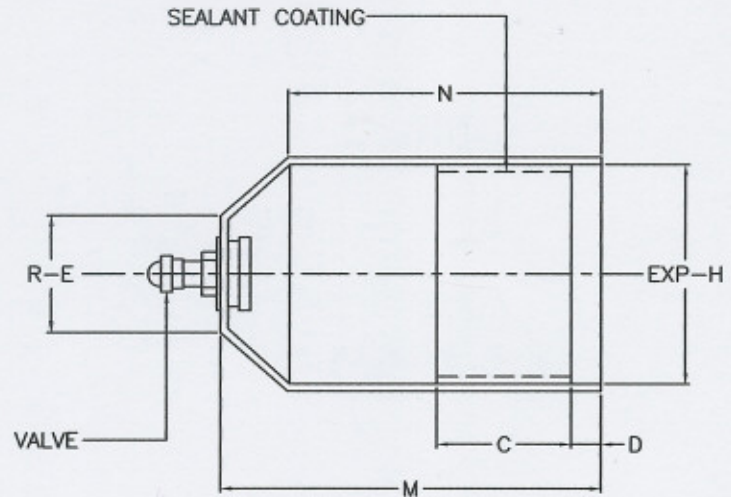

EXPANDED END CAP

END CAP DESIGN

NORMAL MODEL	VALVE MODEL	H	EXP-H	M	N	C	D	R	R-E	W	HW
		S	E	E	E	E	E	S	E	S	S
IXL100	-	4.5	15	45	40	20	5	5	5	2.7	2.3
IXL105	-	6	20	63	58	25	5	7.5	11	2.9	3.1
IXL110	IXL111	8.5	25	70	65	25	5	8	20	3.2	3
IXL120	IXL121	14.5	40	102	92	35	5	12	23	3.2	3.2
IXL130	IXL131	24	63	118	105	50	5	16	25	3.7	3.7
IXL135	IXL135V	32	75	133	113	65	5	16	37	3.7	4.3
IXL140	IXL141	38	78	130	107	65	5	20	31	4.2	4
IXL145	IXL145V	45	106	164	138	75	5	22	48	4.25	4.5
IXL150	IXL151	57	100	155	133	75	5	25	48	4.5	4
IXL160	IXL161	57	120	155	133	75	5	25	48	4.5	4
IXL170	IXL171	57	145	155	133	75	5	25	46	4.75	5

E : DIMENSION WHEN EXPANDED

S : DIMENSION WHEN FULLY RECOVERED

NOTES

1. ALL DIMENSIONS ARE IN MM.

2. TOLERANCES :

THICKNESS	W, HW & T	± 10%
LENGTHS	M, N, C	± 2%
DIAMETERS	H, EXP-H, R-E	± 3%
ANGLES	D	+5, -0

REVISION NO.	6	FIRST ANGLE PROJECTION	SCALE : NTS	ALL DIMENSIONS IN MM.
DATE	02/05/07	DRAWN BY : JARUN P.	APPROVED BY :	SANJEEV NABAR