

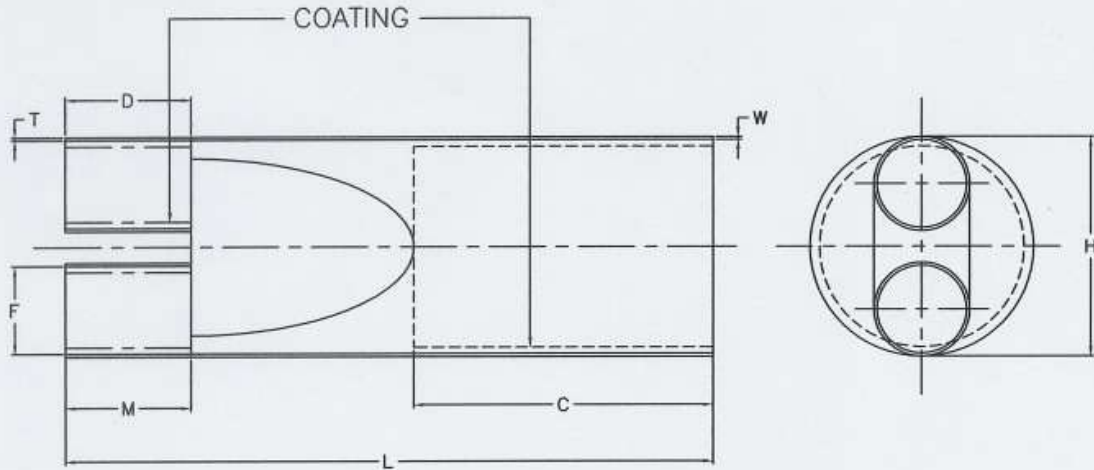

IKEBANA ENGINEERING LIMITED

ENGINEERING DRAWING :
HEAT SHRINKABLE CABLE ACCESSORIES

PRODUCT	2 FINGER LV BREAKOUTS
MODEL	IXL 250 AND IXL 260
DOCUMENT NO.	DR/MFG/250
PAGE	1 OF 1



TWO FINGER BREAKOUTS

MODEL	H	EXP-H	F	EXP-F	L	EXP-L	M	EXP-M	C	D	W	T
LV	S	E	S	E	S	E	S	E	E	S	S	S
IXL 250	10	33	3	14	90	75	20	15	30	20	2	2.3
IXL 260	22	60	6.7	24	120	100	35	25	40	20	3.2	3

E : DIMENSION WHEN EXPANDED

S : DIMENSION WHEN FULLY RECOVERED

NOTES

1. ALL DIMENSIONS ARE IN MM.

2. TOLERANCES :

THICKNESS	W & T	± 10%
LENGTHS	L,M,EXP-M,C&D	± 10%
DIAMETERS	H,EXP-H,F,EXP-F	± 5%

REVISION NO.	2	FIRST ANGLE PROJECTION	SCALE : NTS	ALL DIMENSIONS IN MM.
DATE	02/08/04	DRAWN BY :	JARUN P.	APPROVED BY : SANJEEV NABAR



IKEBANA ENGINEERING LIMITED
 ENGINEERING DRAWING :
 HEAT SHRINKABLE CABLE ACCESSORIES

PRODUCT	3 FINGER LV BREAKOUTS
MODEL	IXL 350 TO IXL 390
DOCUMENT NO.	DR/MFG/350
PAGE	1 OF 1

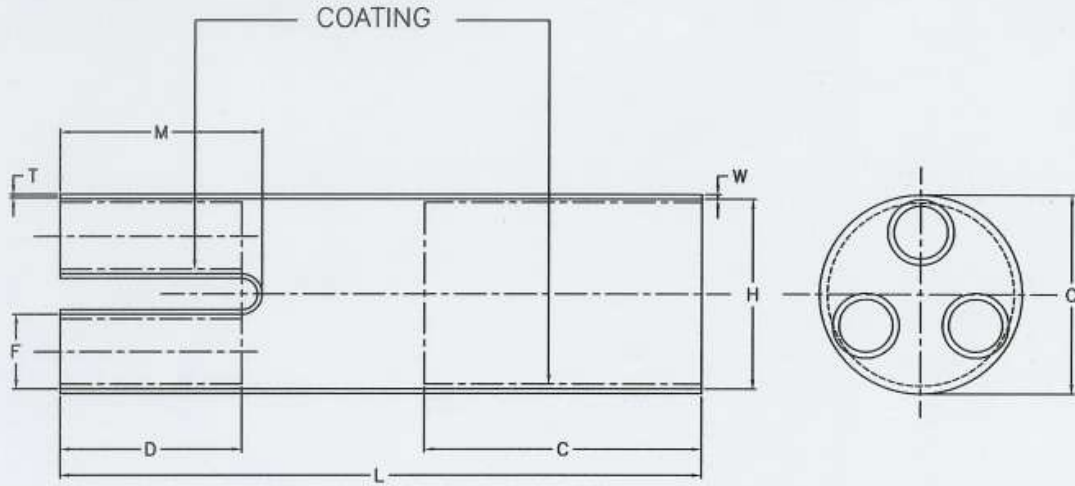

THREE FINGER LV BREAKOUTS DESIGN

MODEL	H	EXP-H	F	EXP-F	O	L	M	N	C	D	W	T
LV	S	E	S	E	S	S	S	S	E	E	S	S
IXL350	14	38	4	15	20	110	20	0	45	20	2.30	1.50
IXL360	22	60	8	26	40	185	45	115	65	40	3.75	3.00
IXL370	33	80	16	36	52	210	50	105	70	40	4.00	3.25
IXL380	47	110	20	48	72	225	75	112	90	55	3.80	3.00
IXL385	47	125	20	55	72	250	75	112	90	55	4.25	3.50
IXL390	54	140	27	62	75	240	65	90	90	45	4.00	2.50

E : DIMENSION WHEN EXPANDED
 S : DIMENSION WHEN FULLY RECOVERED

NOTES

- ALL DIMENSIONS ARE IN MM.
- TOLERANCES :

THICKNESS	W & T	± 10%
LENGTHS	L,M,N&C	± 10%
DIAMETERS	H,EXP-H,F,EXP-F&O	± 5%

REVISION NO.	5	FIRST ANGLE PROJECTION	SCALE : NTS	ALL DIMENSIONS IN MM.
DATE	25/10/06	DRAWN BY :	JARUN P.	APPROVED BY : SANJEEV NABAR



IKEBANA ENGINEERING LIMITED

ENGINEERING DRAWING :
HEAT SHRINKABLE CABLE ACCESSORIES

PRODUCT	4 FINGER LV BREAKOUTS
MODEL	IXL 410 TO IXL 450
DOCUMENT NO.	DR/MFG/400
PAGE	1 OF 1

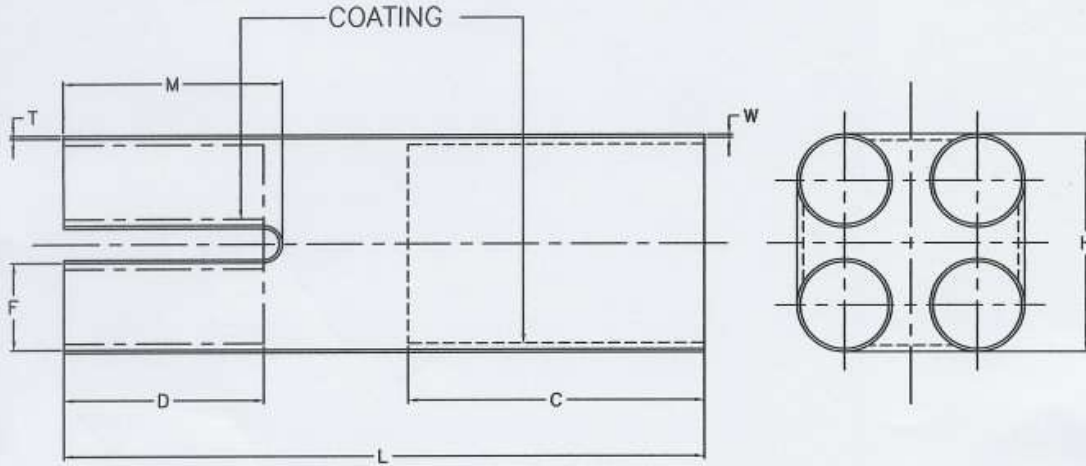

FOUR FINGER BREAKOUTS

MODEL	H	EXP-H	F	EXP-F	L	EXP-L	M	EXP-M	C	D	W	T
LV	S	E	S	E	S	E	S	E	E	E	S	S
IXL410	14	38	3.2	15	105	90	25	20	40	20	2.5	1.5
IXL415	14	50	3.2	15	105	90	25	20	40	20	2.5	1.5
IXL420	25	55	6.0	20	180	165	45	40	60	25	4.0	3.0
IXL425	25	65	6.0	25	180	160	45	35	60	25	4.0	3.0
IXL430	22	72	8.5	25	190	165	45	40	65	25	4.0	3.0
IXL440	33	100	14	35	215	180	50	40	75	30	4.0	3.0
IXL450	47	125	20	45	245	200	72	50	100	30	4.5	3.0

E : DIMENSION WHEN EXPANDED

S : DIMENSION WHEN FULLY RECOVERED

NOTES

1. ALL DIMENSIONS ARE IN MM.

2. TOLERANCES :

THICKNESS	W & T	± 10%
LENGTHS	L,M,EXP-M,C&D	± 10%
DIAMETERS	H,EXP-H,F,EXP-F	± 5%

REVISION NO.	5	FIRST ANGLE PROJECTION	SCALE : NTS	ALL DIMENSIONS IN MM.
DATE	15/07/06	DRAWN BY :	JARUN P.	APPROVED BY : SANJEEV NABAR